

Cable Carrier T100.50 C/R

Produced in Nylon - Standard color: Black;
Temperature range: -30° ~120°C;

Opening system that facilitates changes and
maintenances of the cables and hoses.

Model with cables separator;

Model with reinforcing rivets.

*Recommended for hydraulic cables or for cable
carriers with more than 4 meters length.

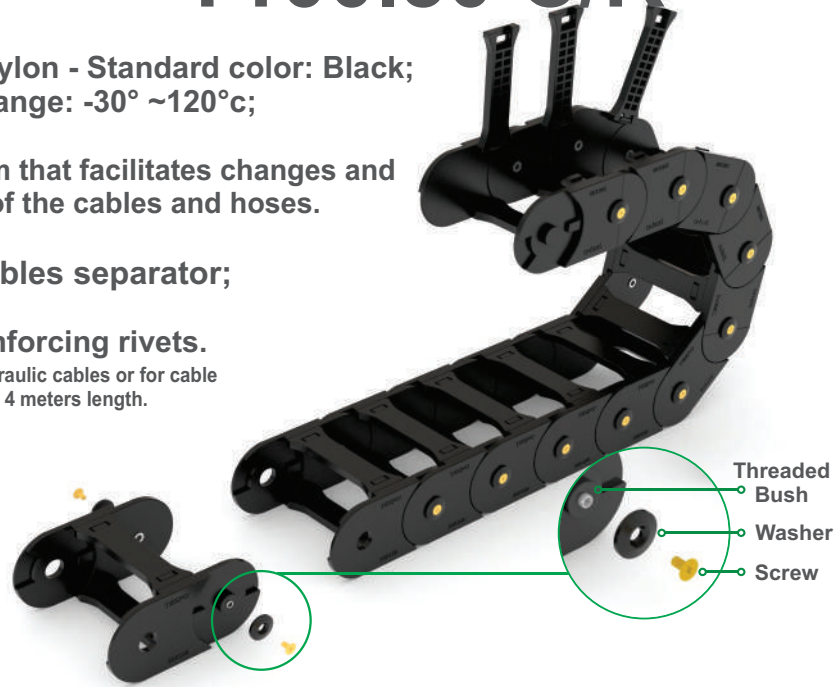

Technical Specifications

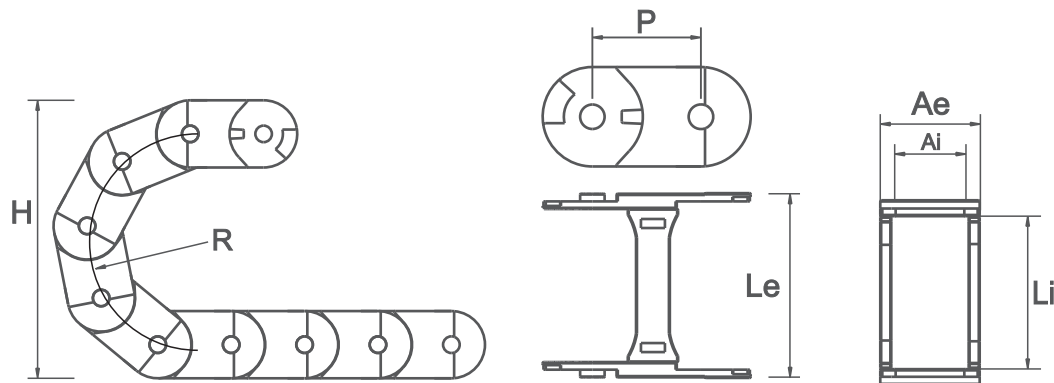

CODE	DESCRIPTION	INNER DIMENSIONS (Li x Ai)	EXTERNAL DIMENSIONS (Le x Ae)	HEIGHT (H)	RADIUS (R)	PITCH (P)	LINKS/ METRO	WEIGHT/ METRO
03698	CABLE CARRIER T100.50.R100mm WITH REINFORCEMENTS	100x50	128X65	270	100	71	14	2195gr
03699	CABLE CARRIER T100.50.R150mm WITH REINFORCEMENTS	100x50	128X65	370	150	71	14	2195gr

Mounting bracket

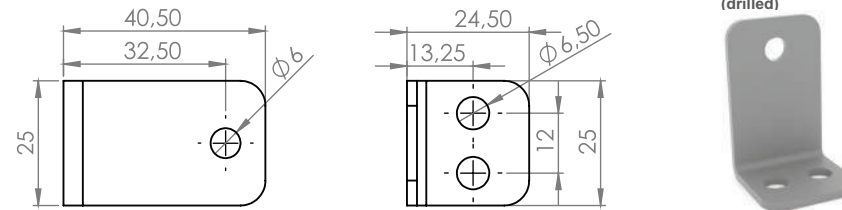
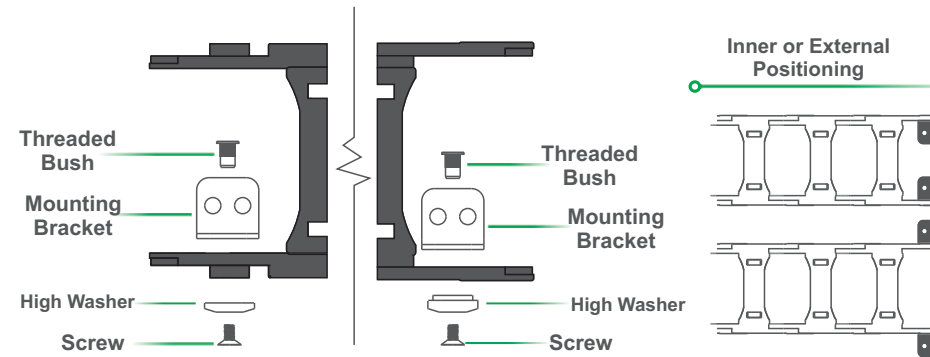
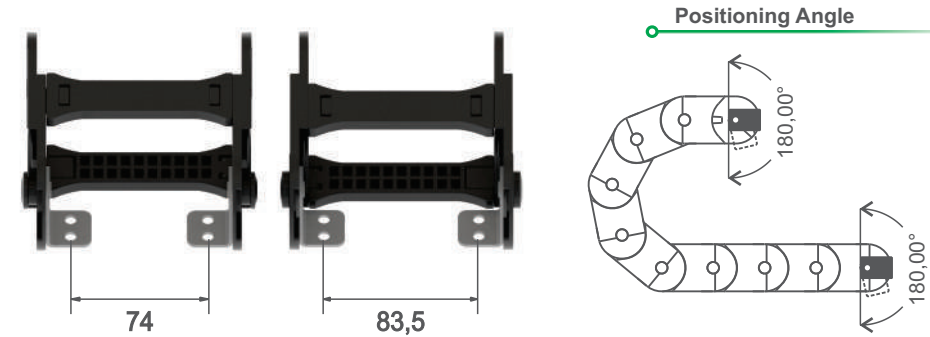

CODE	DESCRIPTION	INNER DIMENSIONS (Li x Ai)	EXTERNAL DIMENSIONS (Le x Ae)
03719	MOUNTING BRACKET SET	100x50	129X65

*Unit of measurement: millimeters

Cables Separator (Cód. 03558)

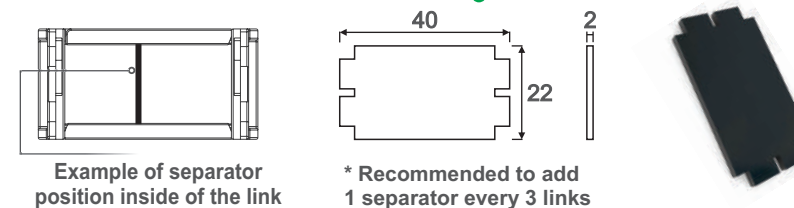

Example of separator
position inside of the link

* Recommended to add
1 separator every 3 links

Assembly Plan

Step 1

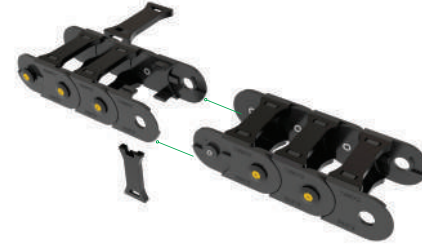

Step 2

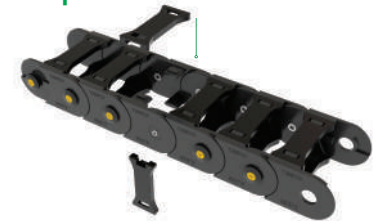

Step 3



Final Assembly

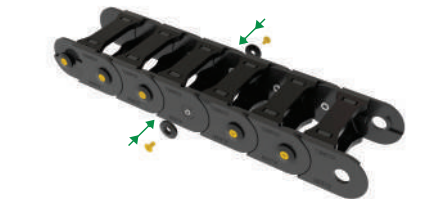

*Optional wrench is available to
help during assembly process
(Cód.03684)

