

Cable Carrier T125.50, C/R

Produced in Nylon - Standard color: Black;
Temperature range: -30° ~120°C;

Opening system that facilitates changes and
maintenances of the cables and hoses.

Model with cables separator;

Model with reinforcing rivets.

*Recommended for hydraulic cables or for cable
carriers with more than 4 meters length.

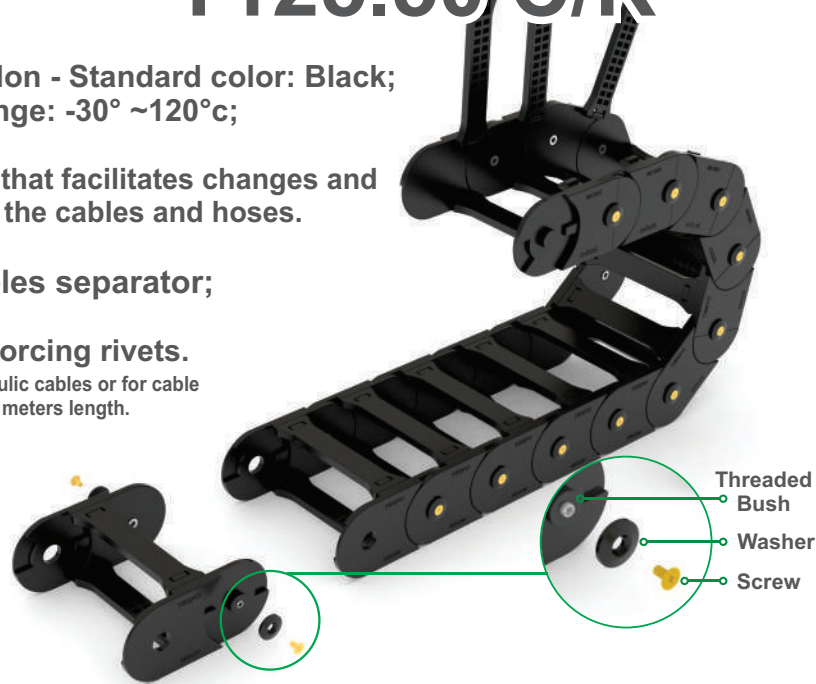

Technical Specifications

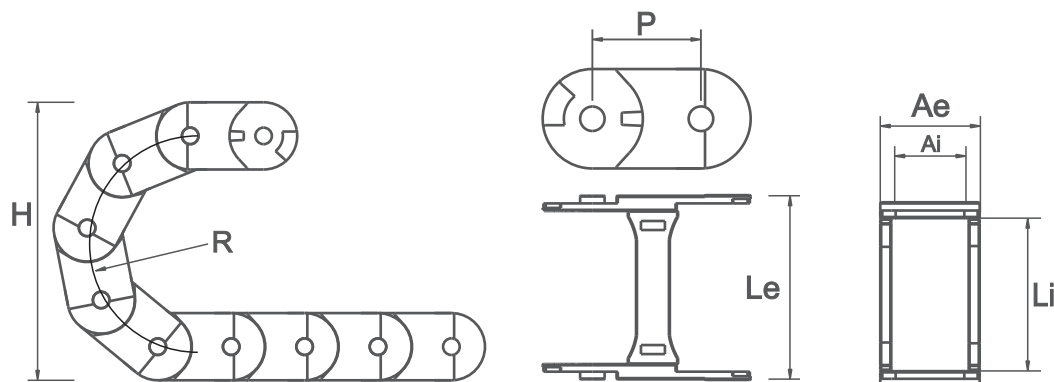

CODE	DESCRIPTION	INNER DIMENSIONS (Li x Ai)	EXTERNAL DIMENSIONS (Le x Ae)	HEIGHT (H)	RADIUS (R)	PITCH (P)	LINKS/ METRO	WEIGHT/ METRO
03700	CABLE CARRIER T125.50.R100mm WITH REINFORCEMENTS	125x50	153X65	270	100	71	14	2340gr
03701	CABLE CARRIER T125.50.R150mm WITH REINFORCEMENTS	125x50	153X65	370	150	71	14	2340gr

Mounting bracket

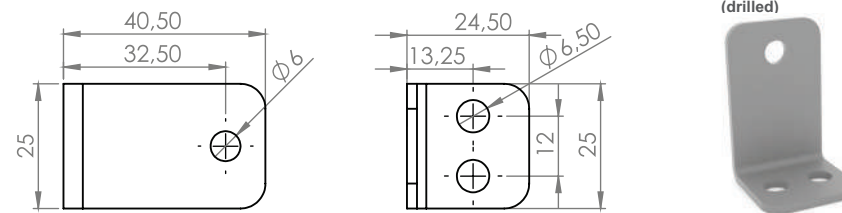
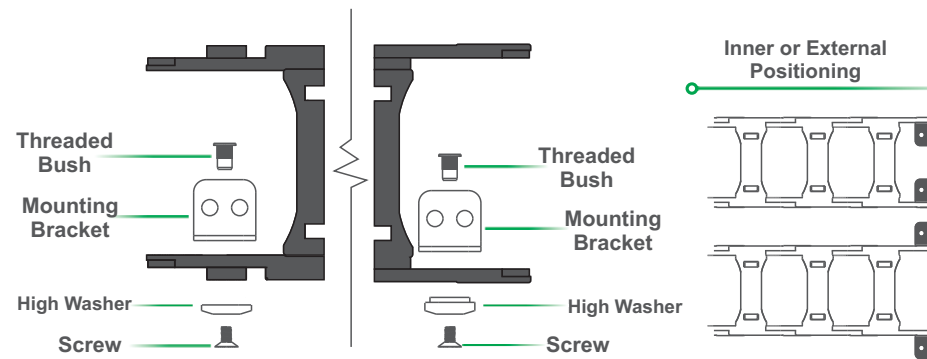
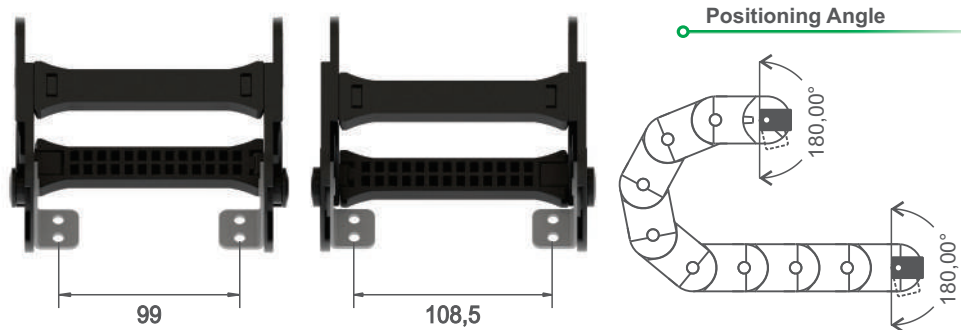

CODE	DESCRIPTION	INNER DIMENSIONS (Li x Ai)	EXTERNAL DIMENSIONS (Le x Ae)
03720	MOUNTING BRACKET SET	125x50	155X65

*Unit of measurement: milimeters

Cables Separator (Cód. 03558)

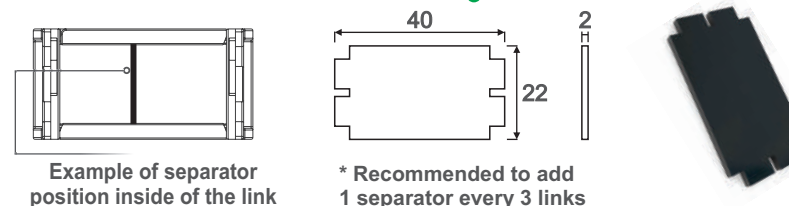

Example of separator
position inside of the link

* Recommended to add
1 separator every 3 links

Assembly Plan

Step 1

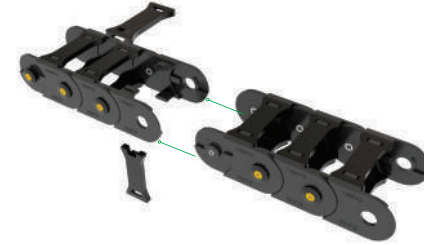

Step 2



Step 3



Final Assembly

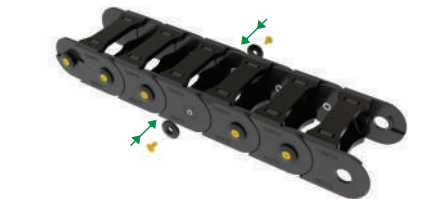

*Optional wrench is available to
help during assembly process
(Cód.03684)

