

# Cable Carrier T50.50 C/R

Produced in Nylon - Standard color: Black;  
Temperature range: -30° ~120°C;

Opening system that facilitates changes and  
maintenances of the cables and hoses.

Model with cables separator;

Model with reinforcing rivets.

\*Recommended for hydraulic cables or for cable  
carriers with more than 4 meters length.

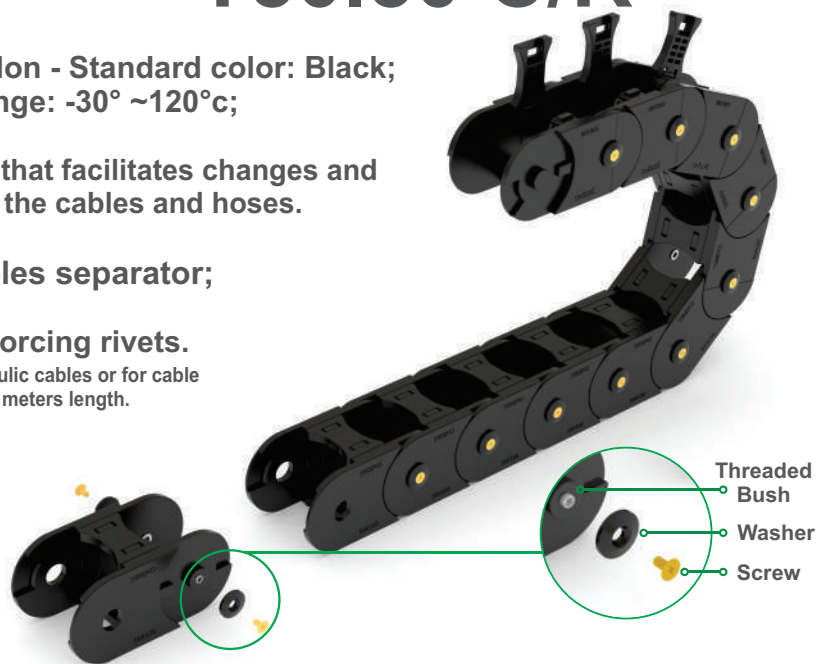

## Technical Specifications

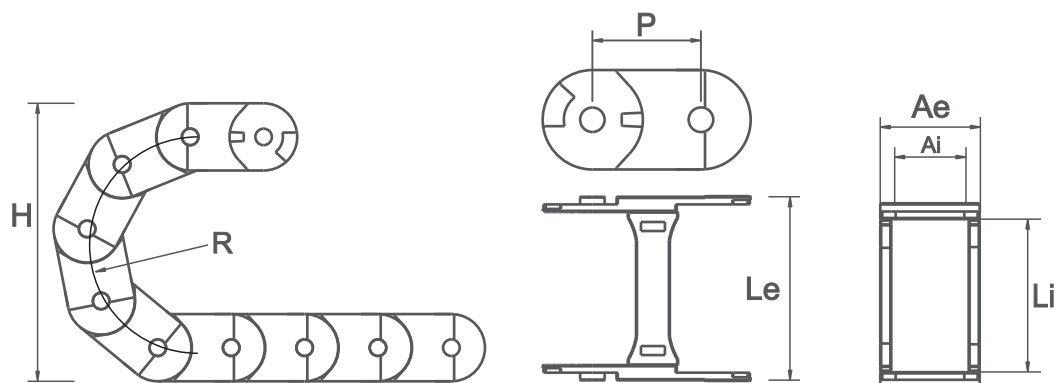

CODE	DESCRIPTION	INNER DIMENSIONS (Li x Ai)	EXTERNAL DIMENSIONS (Le x Ae)	HEIGHT (H)	RADIUS (R)	PITCH (P)	LINKS/ METRO	WEIGHT/ METRO
03694	CABLE CARRIER T50.50.R100mm WITH REINFORCEMENTS	50X50	77X65	270	100	71	14	1970gr
03695	CABLE CARRIER T50.50.R150mm WITH REINFORCEMENTS	50X50	77X65	370	150	71	14	1970gr

## Mounting bracket

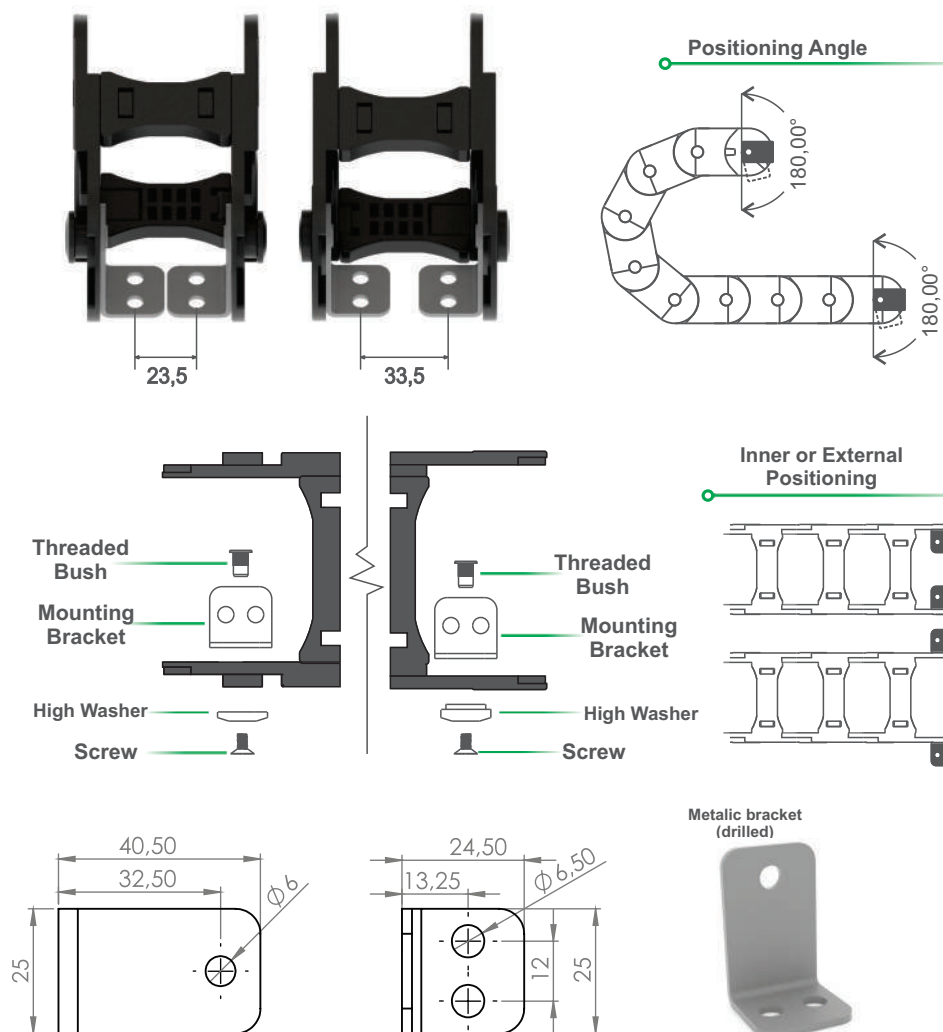

CODE	DESCRIPTION	INNER DIMENSIONS (Li x Ai)	EXTERNAL DIMENSIONS (Le x Ae)
03702	MOUNTING BRACKET SET	50X50	79X65

\*Unit of measurement: milimeters

## Cables Separator (Cód. 03558)

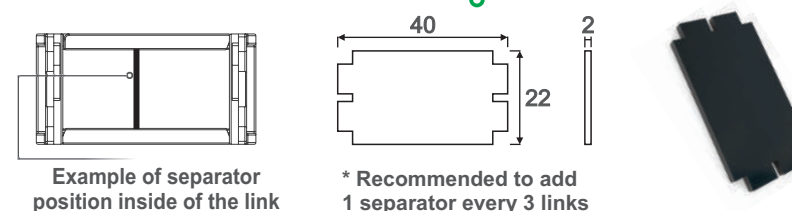

## Assembly Plan

### Step 1

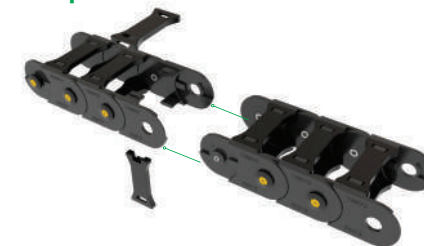

### Step 2



### Step 3



### Final Assembly



\*Optional wrench is available to  
help during assembly process  
(Cód.03684)

