

# Cable Carrier T50.35 C/R

Produced in Nylon - Standard color: Black;  
Temperature range: -30° ~120°C;

Opening system that facilitates changes and  
maintenances of the cables and hoses.

Model with cables separator;

Model with reinforcing rivets.

\*Recommended for hydraulic cables or for cable  
carriers with more than 4 meters length.

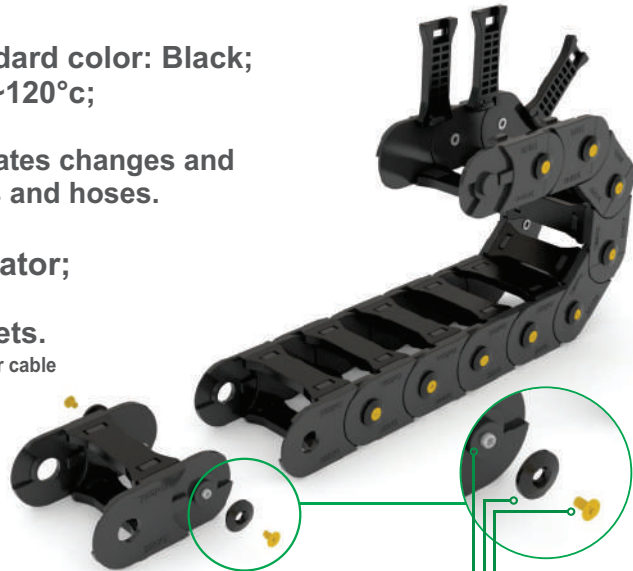

## Technical Specifications

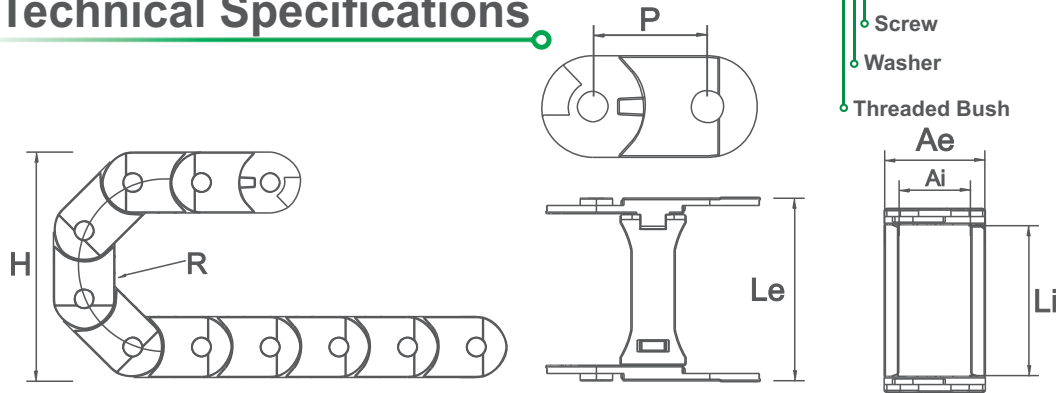

CODE	DESCRIPTION	INNER DIMENSIONS (Li x Ai)	EXTERNAL DIMENSIONS (Le x Ae)	HEIGHT (H)	RADIUS (R)	PITCH (P)	LINKS/ METRO	WEIGHT/ METRO
03660	CABLE CARRIER T50.35 R75mm With REINFORCEMENT	50x35	75x50	185	75	56	18	1475gr
03771	CABLE CARRIER T50.35 R150mm With REINFORCEMENT	50x35	75x50	335	150	56	18	1475gr

\*Unit of measurement: milimeters

## Cables Separator (Cód. 03558)

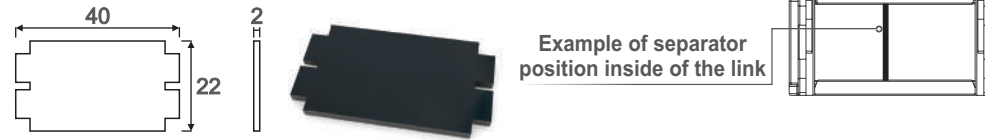

\* Recommended to add  
1 separator every 3 links

## Mounting Brackets

Each cable carrier needs one set of mounting brackets made by two  
brackets. Each bracket should be fixed in each end of the cable carrier.

CODE	DESCRIPTION	INNER DIMENSIONS (Li x Ai)	EXTERNAL DIMENSIONS (Le x Ae)
03468	MOUNTING BRACKETS SET T50.35	50x35	74x50

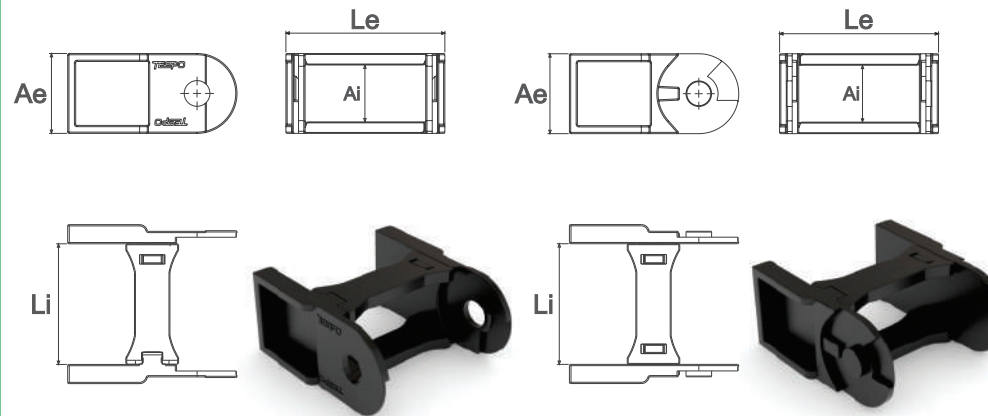

For fixing the mounting brackets, you  
can add holes in the highlighted area.

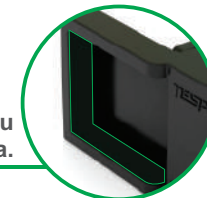

## Assembly Plan

### Step 1

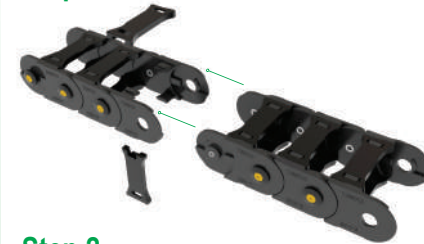

### Step 2



### Step 3



### Final Assembly

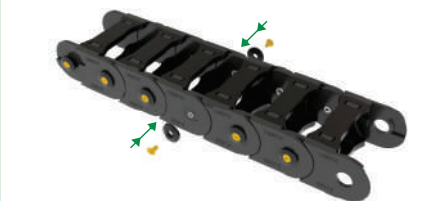

\*Optional wrench is available to  
help during assembly process  
(Cód.03684)

