

# Cable Carrier T100.25 C/R

Produced in Nylon - Standard color: Black;  
Temperature range: -30° ~120°c;

Opening system that facilitates changes and  
maintenances of the cables and hoses.

Model with cables separator;

Model with reinforcing rivets.

\*Recommended for hydraulic cables or for cable  
carriers with more than 4 meters length.

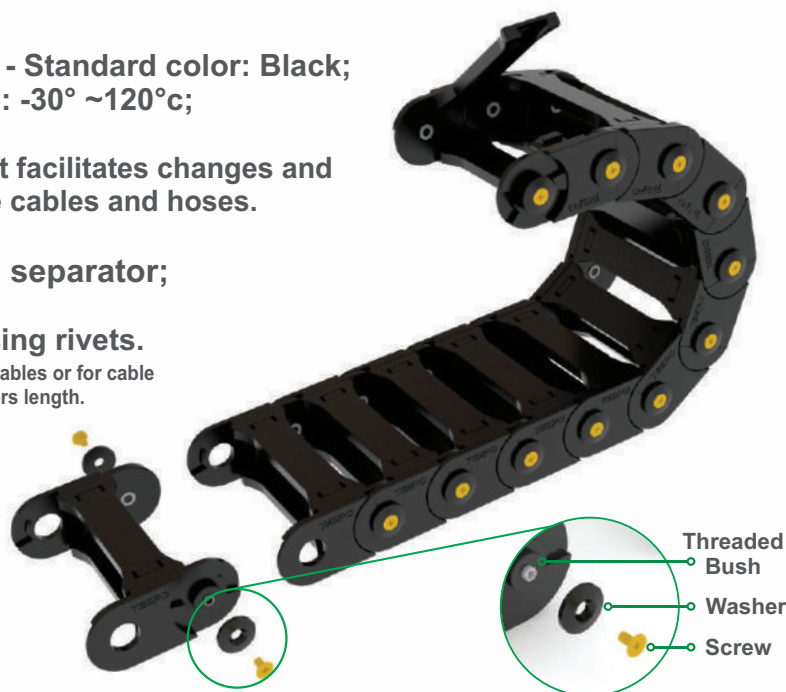

## Technical Specifications

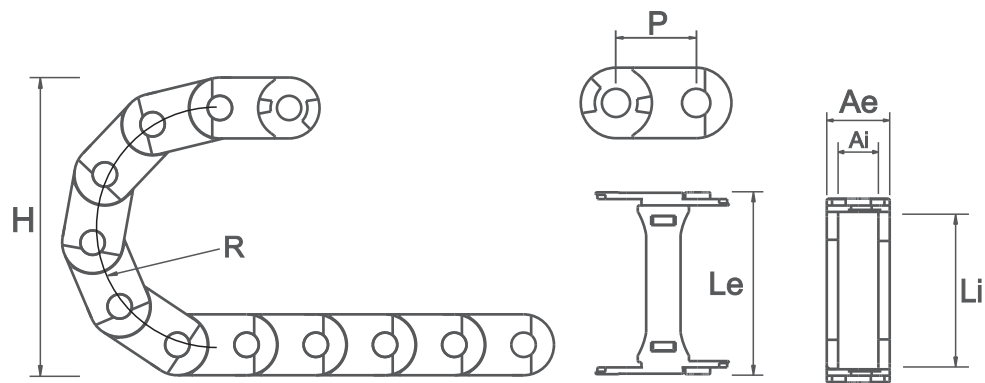

CODE	DESCRIPTION	INNER DIMENSIONS (Li x Ai)	EXTERNAL DIMENSIONS (Le x Ae)	HEIGHT (H)	RADIUS (R)	PITCH (P)	LINKS/ METER	WEIGHT/ METER
03852	CABLE CARRIER T50.25.R75 WITH REINFORCEMENTS	100X25	126X40	190	75	46	22	1694gr
03853	CABLE CARRIER T50.25.R100 WITH REINFORCEMENTS	100X25	126X40	240	100	46	22	1694gr

## Mounting bracket

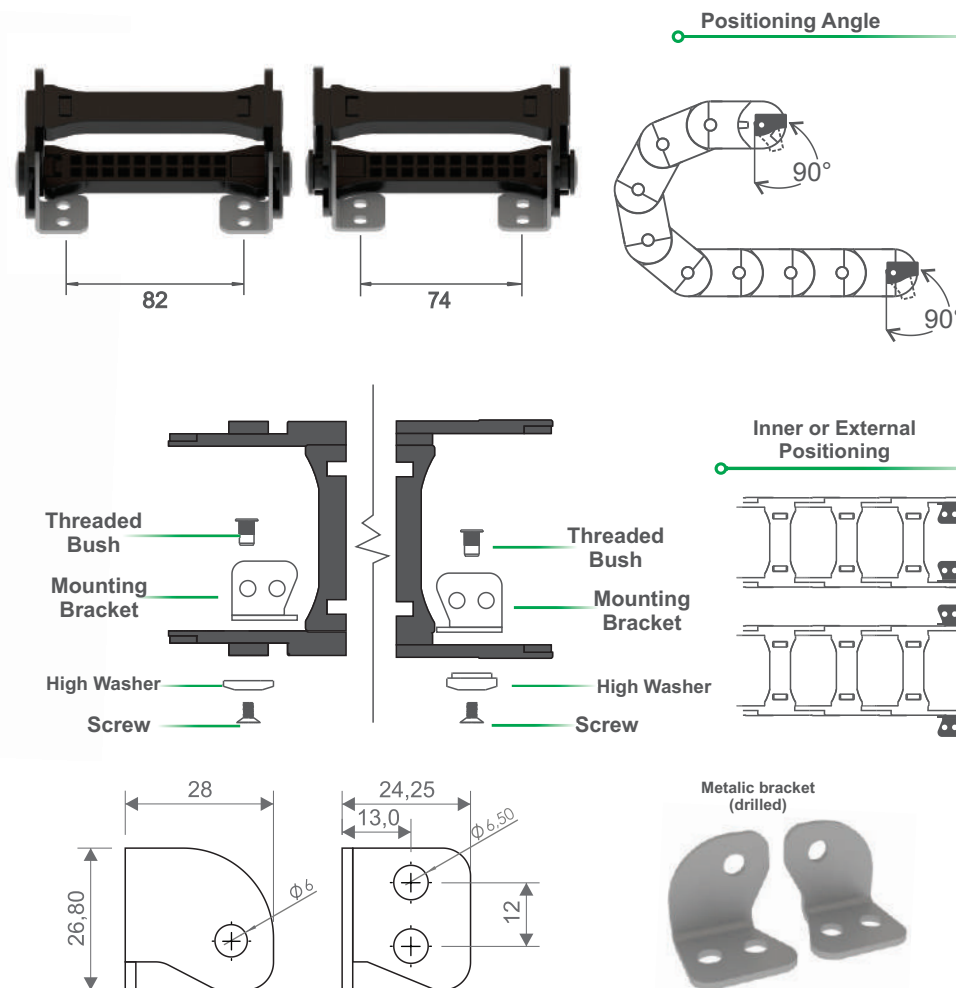

CODE	DESCRIPTION	INNER DIMENSIONS (Li x Ai)	EXTERNAL DIMENSIONS (Le x Ae)
03858	MOUNTING BRACKET SET	100X25	126X40

\*Unit of measurement: milimeters

## Cables Separator (Cód. 03860)

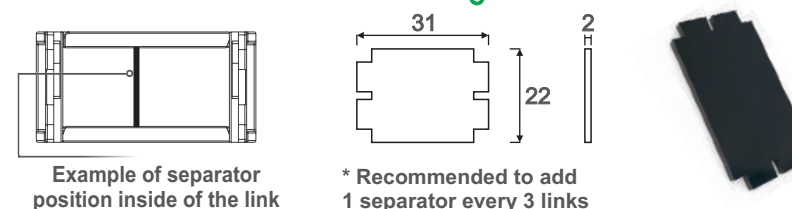

Example of separator  
position inside of the link

\* Recommended to add  
1 separator every 3 links

## Assembly Plan

### Step 1

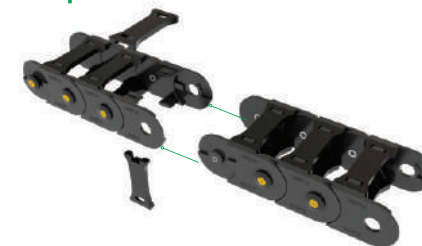

### Step 2



### Step 3



### Final Assembly



\*Optional wrench is available to  
help during assembly process  
(Cód.03684)

