

# Cable Carrier T100.25

Produced in Nylon - Standard color: Black;  
Temperature range: -30° ~120°C;

Opening system that facilitates changes and  
maintenances of the cables and hoses.

Model with cables separator;



## Technical Specifications

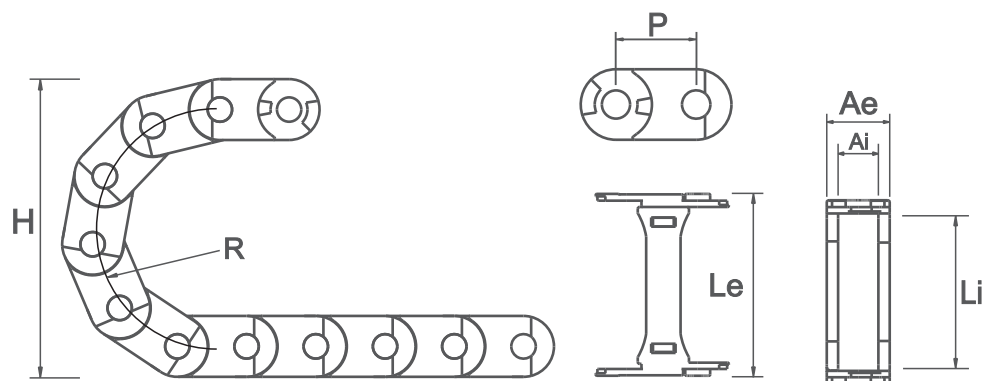

CODE	DESCRIPTION	INNER DIMENSIONS (Li x Ai)	EXTERNAL DIMENSIONS (Le x Ae)	HEIGHT (H)	RADIUS (R)	PITCH (P)	LINKS/ METER	WEIGHT/ METER
03844	CABLE CARRIER T50.25.R75	100X25	117X40	190	75	46	22	1562gr
03845	CABLE CARRIER T50.25.R100	100X25	117X40	240	100	46	22	1562gr

## Mounting bracket

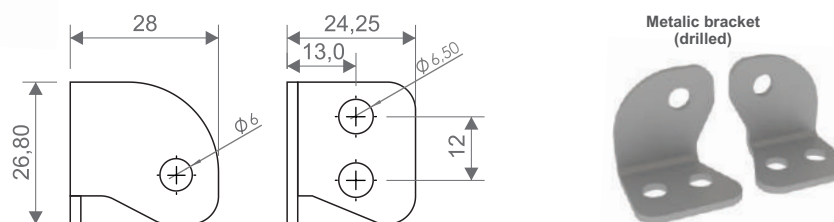
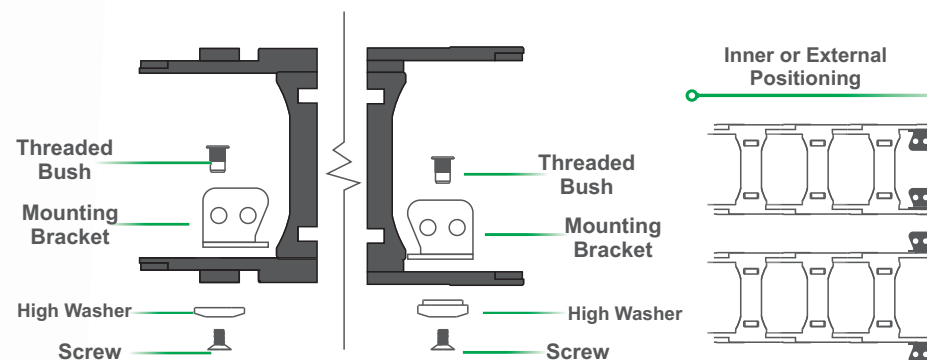
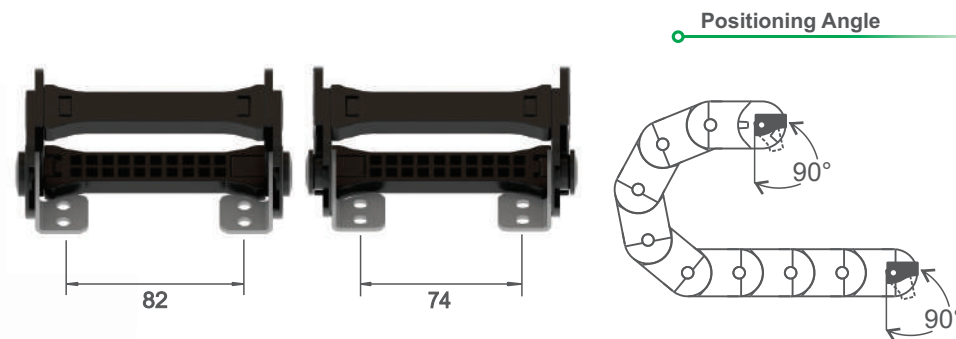

CODE	DESCRIPTION	INNER DIMENSIONS (Li x Ai)	EXTERNAL DIMENSIONS (Le x Ae)
03858	MOUNTING BRACKET SET	100X25	126X40

\*Unit of measurement: millimeters

## Cables Separator (Cód. 03860)

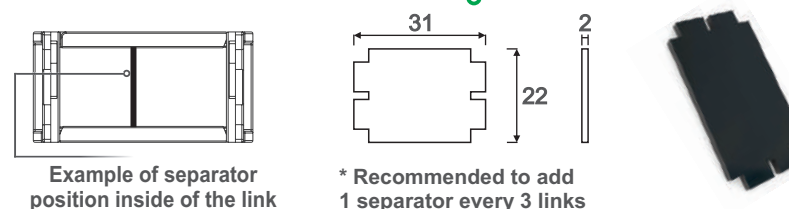

## Assembly Plan

Step 1



Step 2

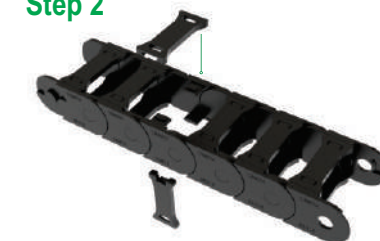

Step 3



Final Assembly

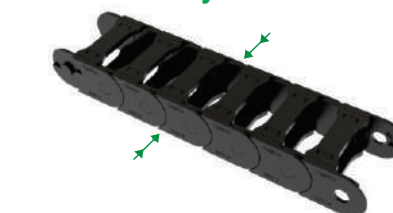

\*Optional wrench is available to help during assembly process (Cód.03684)

