

Cable Carrier T125.25 C/R

Produced in Nylon - Standard color: Black;
Temperature range: -30° ~120°c;

Opening system that facilitates changes and
maintenances of the cables and hoses.

Model with cables separator;

Model with reinforcing rivets.

*Recommended for hydraulic cables or for cable
carriers with more than 4 meters length.

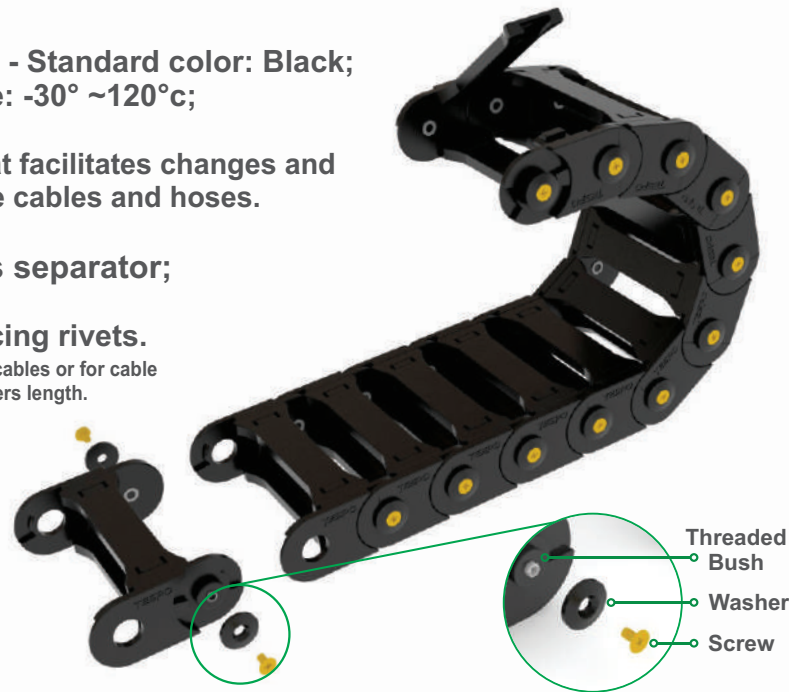

Technical Specifications

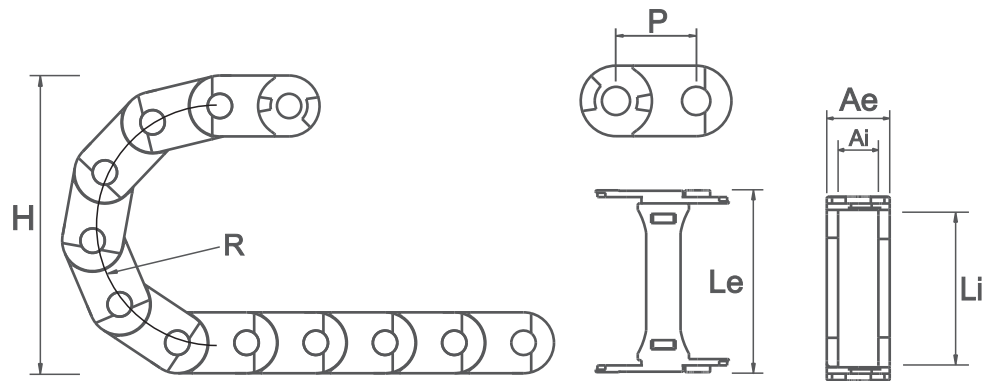

CODE	DESCRIPTION	INNER DIMENSIONS (Li x Ai)	EXTERNAL DIMENSIONS (Le x Ae)	HEIGHT (H)	RADIUS (R)	PITCH (P)	LINKS/ METER	WEIGHT/ METER
03854	CABLE CARRIER T50.25.R75 WITH REINFORCEMENTS	125X25	151X40	190	75	46	22	1892gr
03855	CABLE CARRIER T50.25.R100 WITH REINFORCEMENTS	125X25	151X40	240	100	46	22	1892gr

Mounting bracket

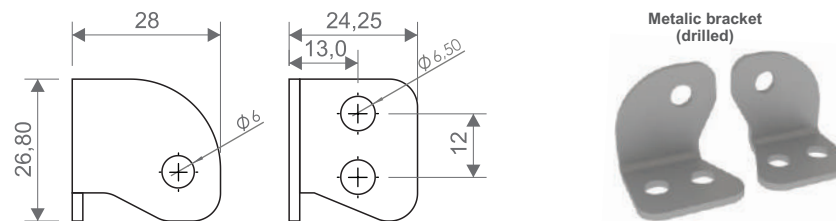
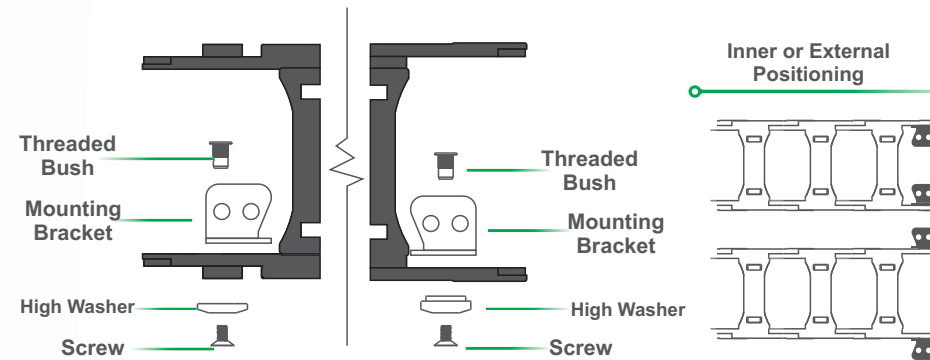
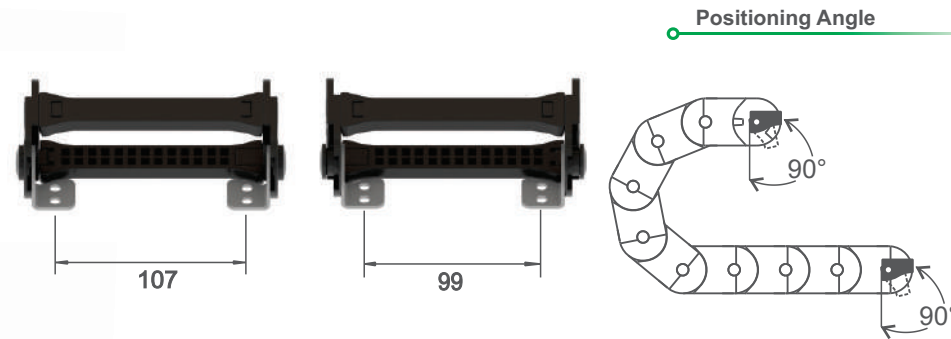

CODE	DESCRIPTION	INNER DIMENSIONS (Li x Ai)	EXTERNAL DIMENSIONS (Le x Ae)
03859	MOUNTING BRACKET SET	125X25	151X40

*Unit of measurement: millimeters

Cables Separator (Cód. 03861)

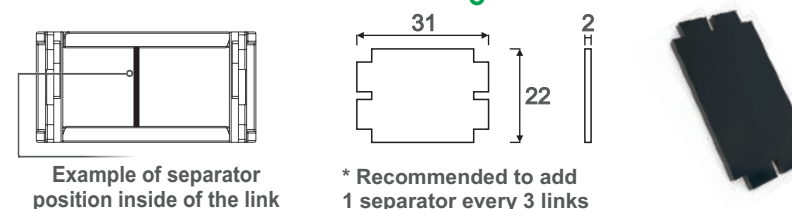

Assembly Plan

Step 1

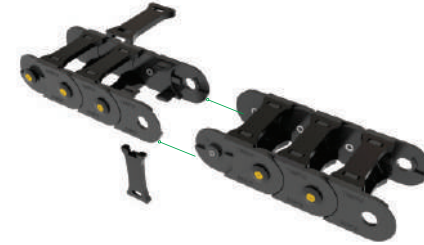

Step 2

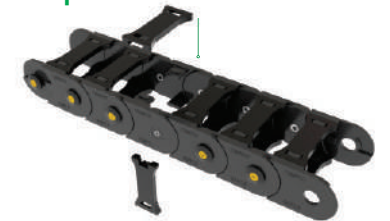

Step 3



Final Assembly

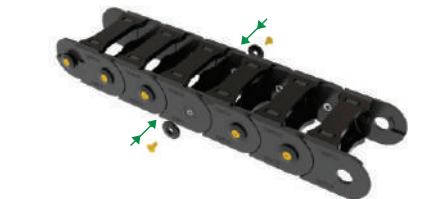

*Optional wrench is available to
help during assembly process
(Cód.03684)

