

Cable Carrier T50.25 C/R

Produced in Nylon - Standard color: Black;
Temperature range: -30° ~120°c;

Opening system that facilitates changes and
maintenances of the cables and hoses.

Model with cables separator;

Model with reinforcing rivets.

*Recommended for hydraulic cables or for cable
carriers with more than 4 meters length.

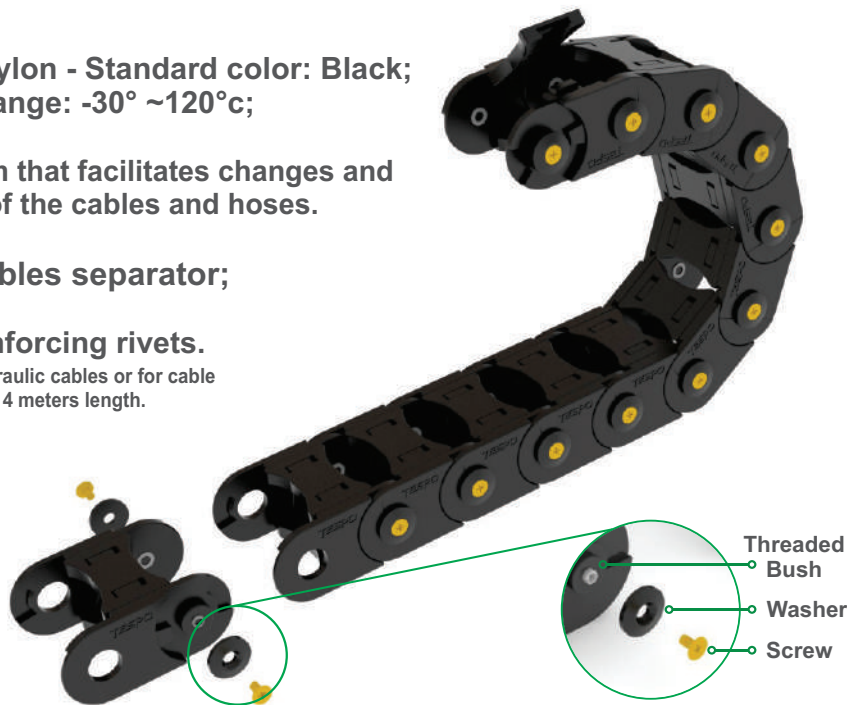

Technical Specifications

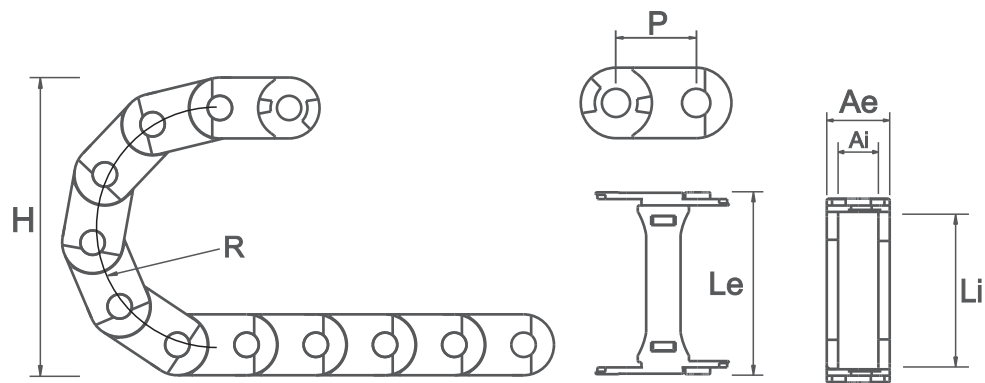

CODE	DESCRIPTION	INNER DIMENSIONS (Li x Ai)	EXTERNAL DIMENSIONS (Le x Ae)	HEIGHT (H)	RADIUS (R)	PITCH (P)	LINKS/ METER	WEIGHT/ METER
03848	CABLE CARRIER T50.25.R75 WITH REINFORCEMENTS	50X25	67X40	190	75	46	22	1364gr
03849	CABLE CARRIER T50.25.R100 WITH REINFORCEMENTS	50X25	67X40	240	100	46	22	1364gr

Mounting bracket

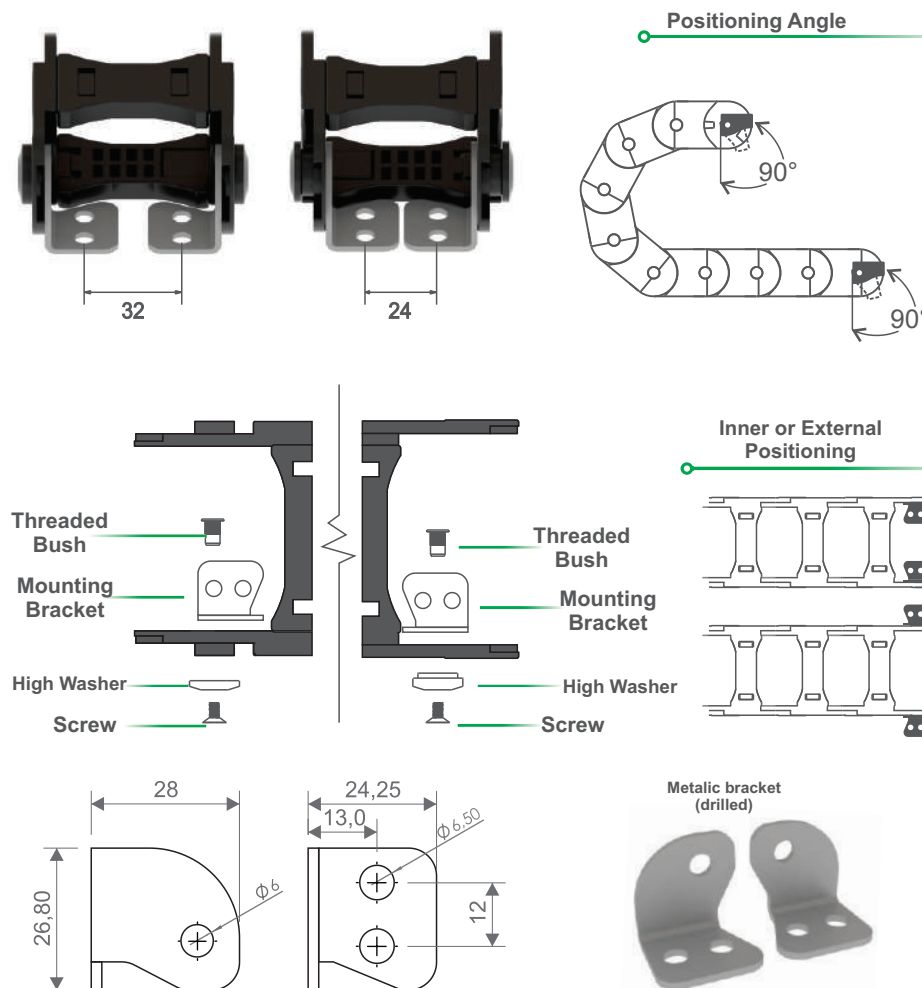

CODE	DESCRIPTION	INNER DIMENSIONS (Li x Ai)	EXTERNAL DIMENSIONS (Le x Ae)
03856	MOUNTING BRACKET SET	50X25	76X40

*Unit of measurement: milimeters

Cables Separator (Cód. 03860)

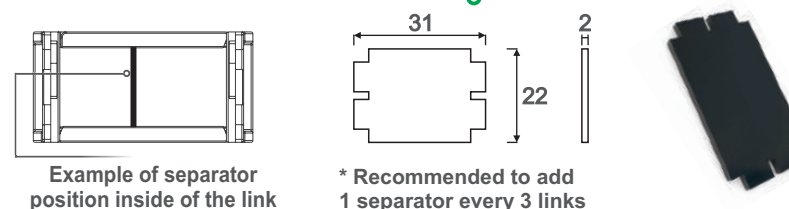

Example of separator
position inside of the link

* Recommended to add
1 separator every 3 links

Assembly Plan

Step 1

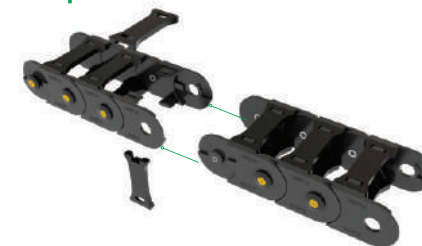

Step 2



Step 3



Final Assembly



*Optional wrench is available to
help during assembly process
(Cód.03684)

