

Cable Carrier T75.25 C/R

Produced in Nylon - Standard color: Black;
Temperature range: -30° ~120°c;

Opening system that facilitates changes and
maintenances of the cables and hoses.

Model with cables separator;

Model with reinforcing rivets.

*Recommended for hydraulic cables or for cable
carriers with more than 4 meters length.

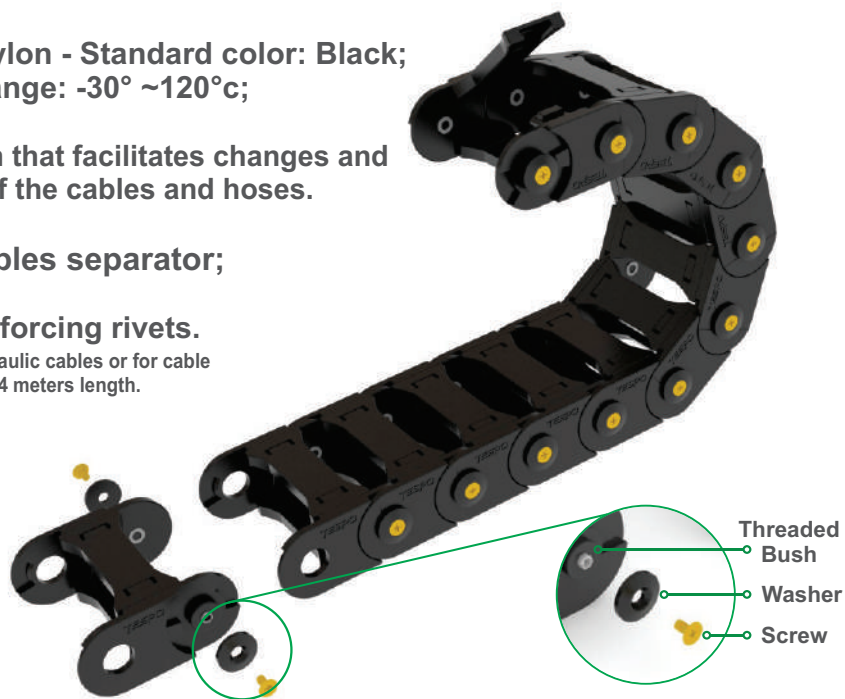

Technical Specifications

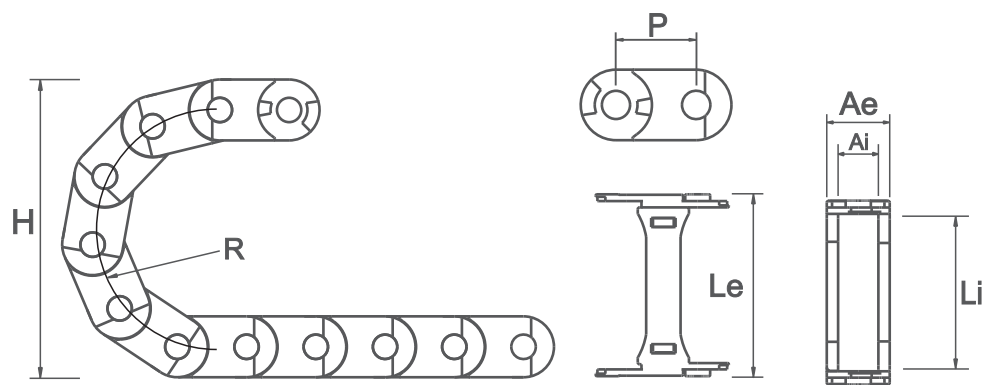

CODE	DESCRIPTION	INNER DIMENSIONS (Li x Ai)	EXTERNAL DIMENSIONS (Le x Ae)	HEIGHT (H)	RADIUS (R)	PITCH (P)	LINKS/ METER	WEIGHT/ METER
03850	CABLE CARRIER T50.25.R75 WITH REINFORCEMENTS	75X25	101X40	190	75	46	22	1540gr
03851	CABLE CARRIER T50.25.R100 WITH REINFORCEMENTS	75X25	101X40	240	100	46	22	1540gr

Mounting bracket

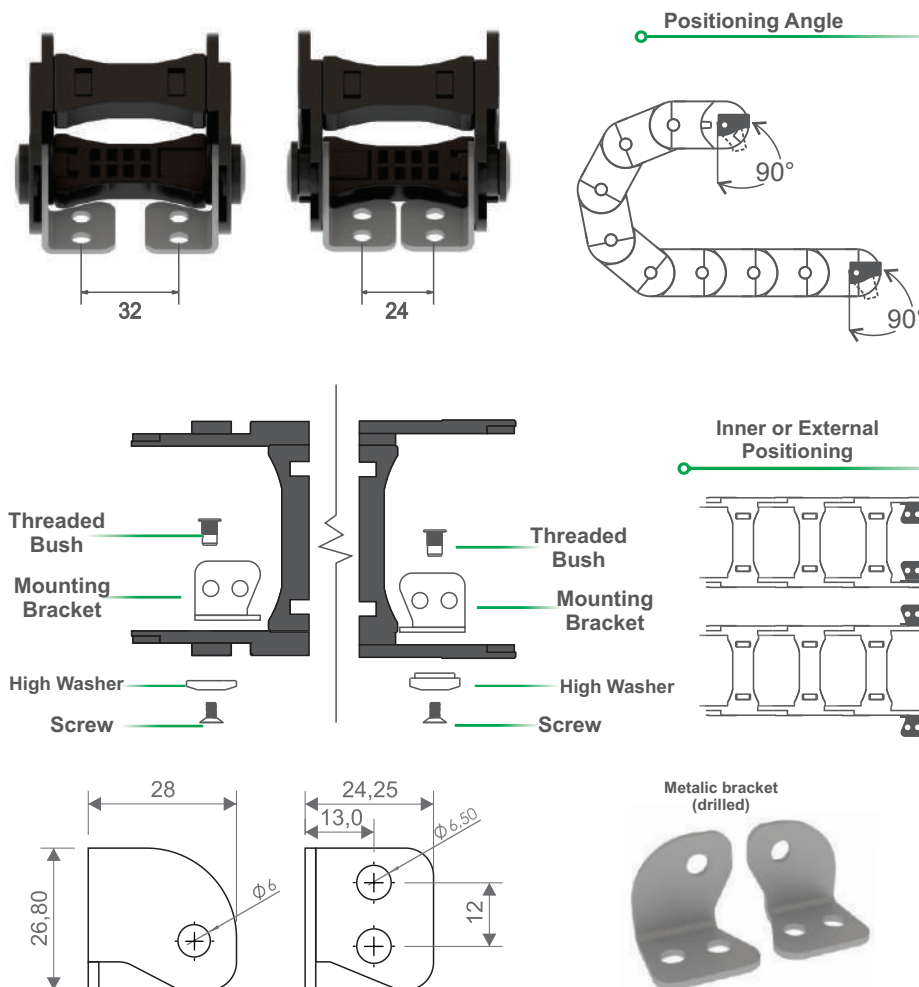

CODE	DESCRIPTION	INNER DIMENSIONS (Li x Ai)	EXTERNAL DIMENSIONS (Le x Ae)
03857	MOUNTING BRACKET SET	75X25	101X40

*Unit of measurement: millimeters

Cables Separator (Cód. 03860)

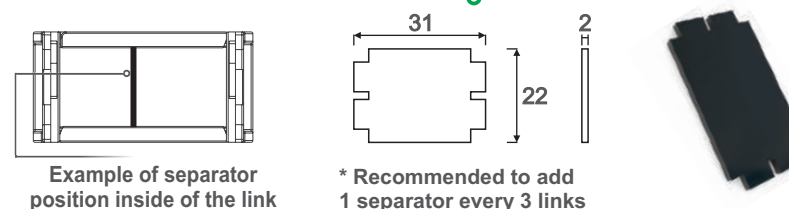

Example of separator
position inside of the link

* Recommended to add
1 separator every 3 links

Assembly Plan

Step 1

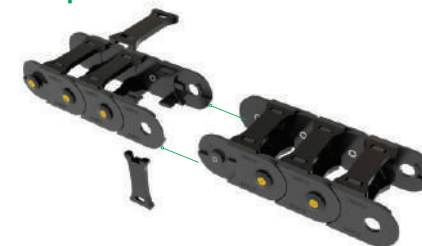

Step 2



Step 3



Final Assembly



*Optional wrench is available to
help during assembly process
(Cód.03684)

