

Cable Carrier T75.25

Produced in Nylon - Standard color: Black;
Temperature range: -30° ~120°C;

Opening system that facilitates changes and
maintenances of the cables and hoses.

Model with cables separator;



Technical Specifications

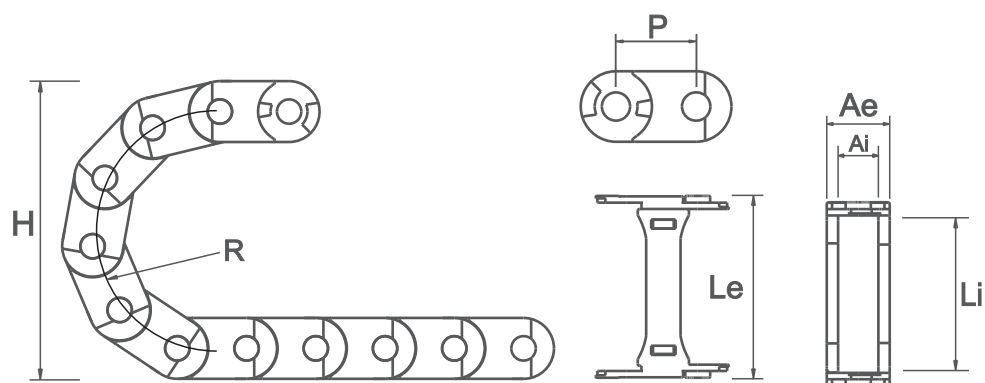

CODE	DESCRIPTION	INNER DIMENSIONS (Li x Ai)	EXTERNAL DIMENSIONS (Le x Ae)	HEIGHT (H)	RADIUS (R)	PITCH (P)	LINKS/ METER	WEIGHT/ METER
03842	CABLE CARRIER T50.25.R75	75X25	92X40	190	75	46	22	1408gr
03843	CABLE CARRIER T50.25.R100	75X25	92X40	240	100	46	22	1408gr

Mounting bracket

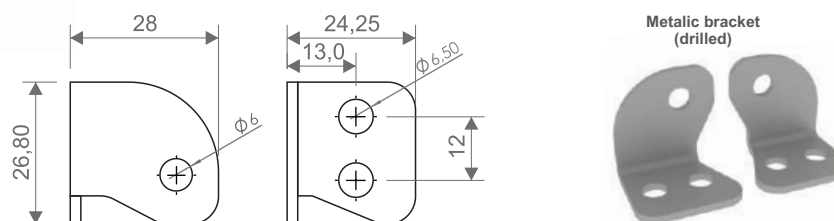
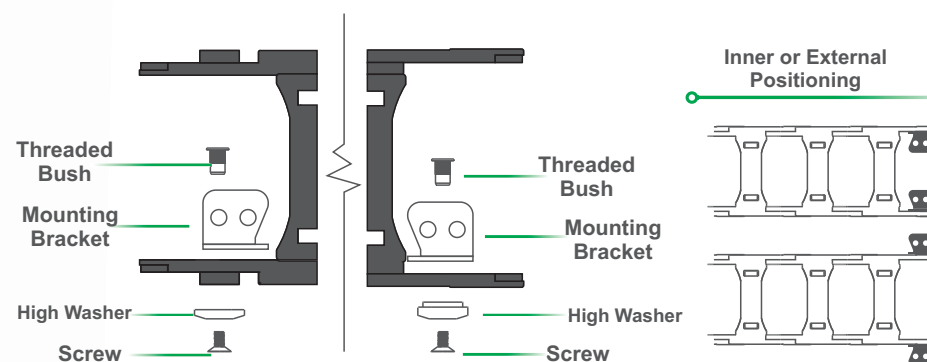
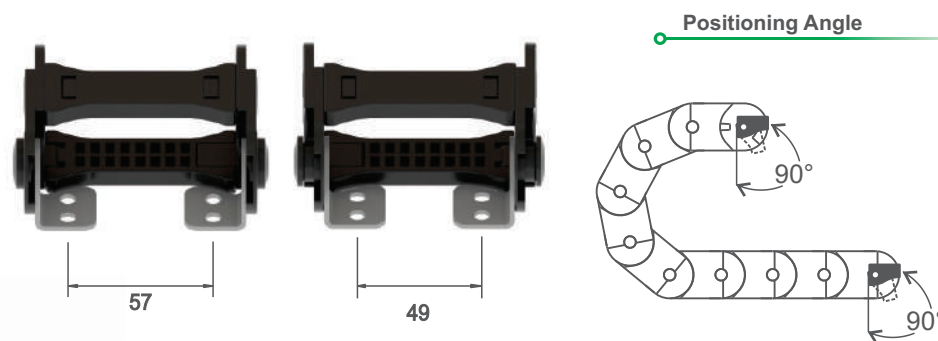

CODE	DESCRIPTION	INNER DIMENSIONS (Li x Ai)	EXTERNAL DIMENSIONS (Le x Ae)
03857	MOUNTING BRACKET SET	75X25	101X40

*Unit of measurement: milimeters

Cables Separator (Cód. 03860)

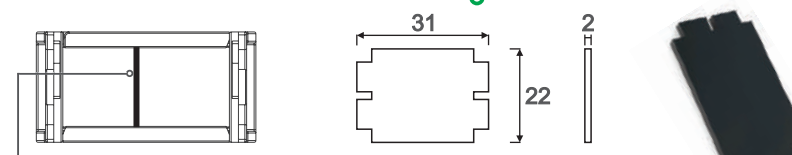

Example of separator
position inside of the link

* Recommended to add
1 separator every 3 links

Assembly Plan

Step 1



Step 2

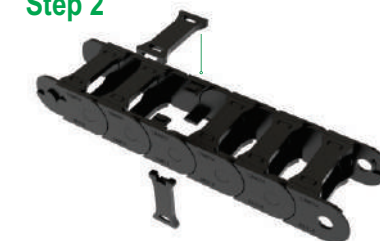

Step 3



Final Assembly

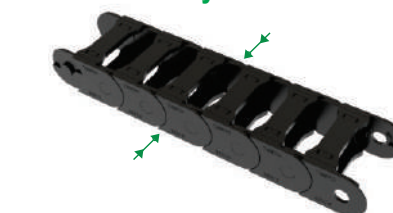

*Optional wrench is available to
help during assembly process
(Cód.03684)

